

Last modification

2023-12-13

MONTEAL PE6 9329501065365



Elevate your home with the Montreal Pendant Family, radiating a contemporary charm through its open lantern design. The black iron frame exudes modern elegance, complemented by a striking gold satin crown. With a tapering silhouette and timeless appeal, this pendant light is available in three sizes, offering versatile options to illuminate your space with style and sophistication.

Overview

Family name	Monteal
Categories	Pendants
Suspension Type	Chain
Usage	Indoor Lighting

Color / Material

Fixture Color	Antique Gold, Black
Fixture Finish	Matte
Fixture Material	Iron

Size

Fixture Length (cm)	35.0
Fixture Width (cm)	105.0
Fixture Height (cm)	25.0
Canopy Length (cm)	8.0
Canopy Projection (cm)	2.5
Canopy Width (cm)	38.0
Suspension Length (cm)	200.0
Height Adjustable?	Yes

Specification

Voltage Input	240V
Total Wattage (max)	150
Wattage	25
Globe Type	E14
Globe / Light Source qty	6
Globe / Light Source included	No

All representations within this document are subject to copyright. ELECTRICAL INSTALLATIONS MUST BE PERFORMED BY A QUALIFIED ELECTRICAL CONTRACTOR AND INSTALLED IN ACCORDANCE WITH AS/NZS 3000.
NOTE : All images , descriptions and dimensions are indicative. Please check latest version of item detail on Telbix website prior to ordering or installation.

Electrical Protection	CLASS I - HIGH VOLTAGE, EARTH REQUIRED
IP rating	IP20
Approvals	RCM
Replacement Warranty	*3 Years

Barcode

GTIN 9329501065365

Image -dimensions

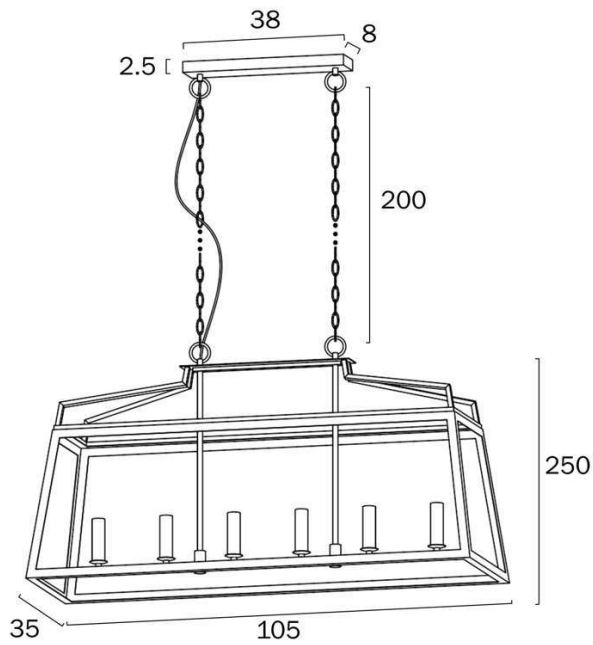

Note: Dimensions are only a guide and may vary due to manufacturing variations.

